



# Lecture #7 of 14

(3: TThF, 5: MTWThF, 4: MTWTh, 2: TW)

Prof. Shane Ardo

Department of Chemistry

University of California Irvine

# Chemical Properties (*let's review TThFMTW*) <sup>124</sup>

- T: Molecular nomenclature, Solutions, Balanced chemical reactions, State functions, Standard states, Thermochemistry
- **Th: Non-ideal gases, Intermolecular forces, Physical properties, Phase changes**
- F: Colligative properties, Water activity, Free energy, (X)Chemical potential, Entropic "force", Activity coefficients, Chemical equilibrium
- **M: van't Hoff equation, Le Chatelier's principle**
- T: Schrödinger equation, Internal energy, Atomic orbitals, Hybridization, Valence bond theory, Molecular orbital theory, Band diagrams
- **W: Crystal field theory, Ligand field theory**



# Charged Interfaces

Prof. Shane Ardo

Department of Chemistry

University of California Irvine

**Quiz Time!**

# Charged Interfaces

- **Vacuum level, Redox half-reactions**
- **Nernst equation**
- **History, Conventions**
- **Electrodes, Potentiostat**
- Electric double layer
- Electric potentials, Liquid-junction potentials, Donnan potential, Membrane potential
- pH probe, Acidity scale, Titrations, Buffering, Henderson–Hasselbalch equation
- Latimer diagram, Pourbaix diagram

Who's best equipped to succeed in EChem?

- (A) Chemists?
- (B) Physicists?
- (C) Chemical Engineers?
- (D) Electrical Engineers?
- (E) Materials Scientists?

Answer: Everyone!... having each of these people in a room is best... **or just one of you all!**

# Vacuum Level and Other Reference States

Hess's law allows one to accurately determine the overall change in a state function ( $\Delta G^{0,\alpha}$ ,  $\Delta H^{0,\alpha}$ ,  $\Delta S^{0,\alpha}$ , etc.) via knowledge of the change in the state function for intermediate steps...

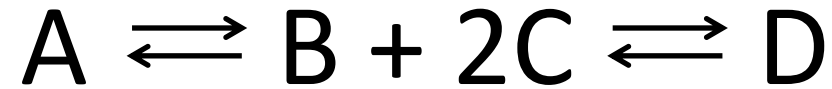

Just add'em up!... *is this concept easy, medium, or hard for you?*

... Good!... and we learned that sometimes it helps to think of a reaction moving species to the local vacuum level to form intermediates... *a reference state loved by physicists*... and then putting the species back into the system... even though that does not happen in practice...

... *is this concept easy, medium, or hard for you?*

... Good, again!... given that, **reduction potentials** and **acidity** should be easy for you to grasp, since they follow directly from these ways of thinking...

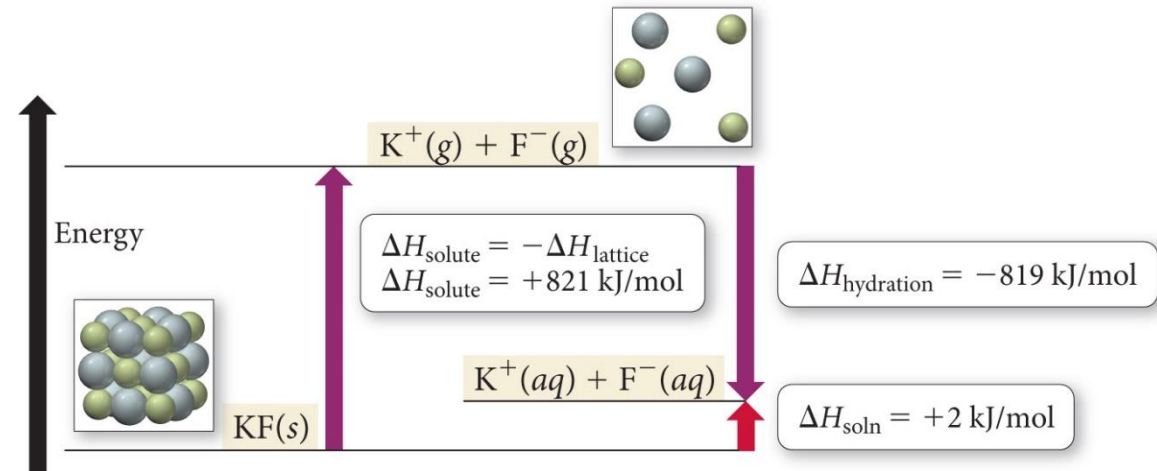

# Gas-Phase Chemistry Terminology

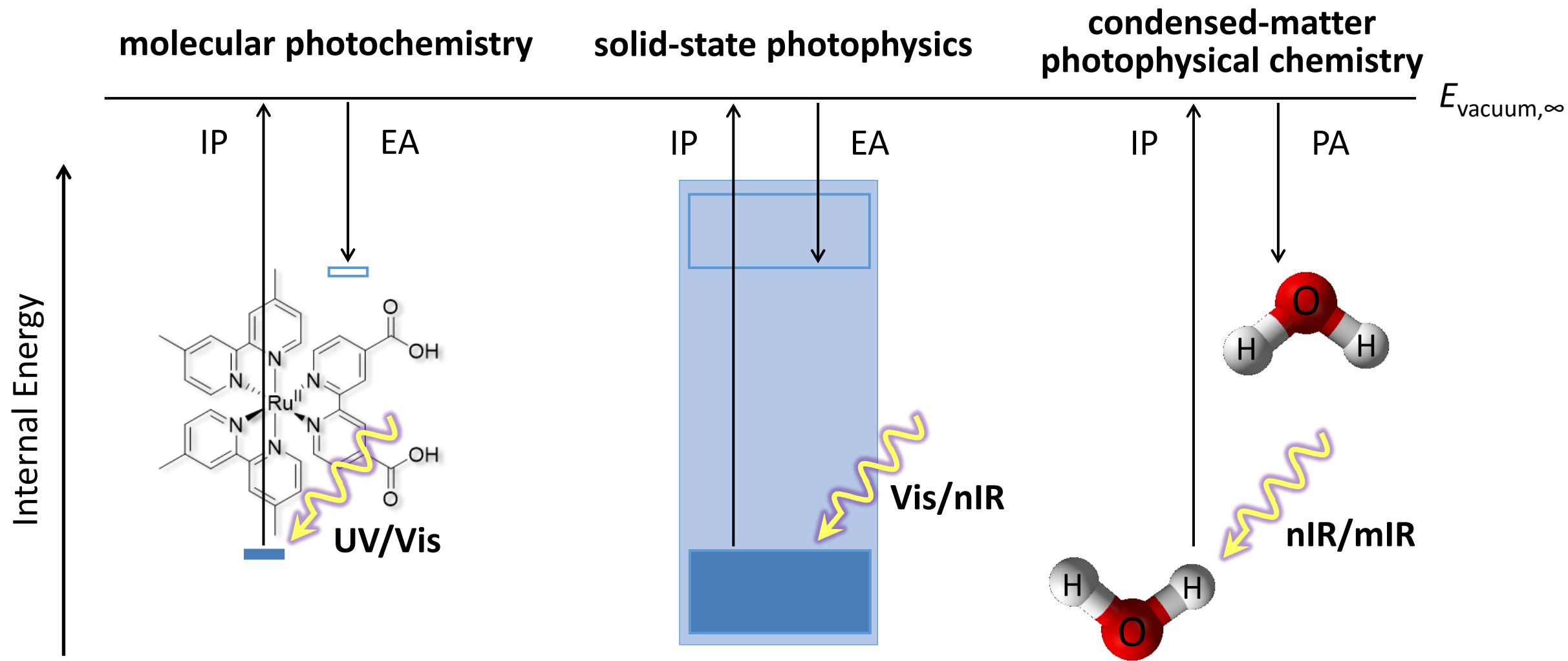

... is this most relevant to **internal energy (Schrodinger equation)** or **free energy (reactivity)**?

# Red–Ox (Redox) Half-Reactions

Each reduction half-reaction is referenced to something...

$$E_{\text{cell}} = E_{\text{red}} - E_{\text{ox}} = -\Delta G/nF$$

Since the method of half-reactions ultimately results in us taking their difference, we can add an arbitrary constant to all half-reactions... by one (somewhat arbitrary) convention, many standard tables assume that  $E^\circ$  for the standard hydrogen electrode (**SHE**) is equal to zero, and that a hypothetical SHE has 1 atm  $\text{H}_2$  (standard state) and  $a_{\text{H}^+} = 1$ .

## Half-Reaction for evolution of hydrogen gas ( $\text{H}_2$ ) (SHE):



$$E_{\text{H}_2} = E_{\text{H}_2}^\circ + \frac{RT}{F} \ln \frac{\sqrt{p_{\text{H}_2}}}{[\text{H}^+]} \quad E_{\text{H}_2}^\circ = 0$$

... anyway, potentials for half-cell reactions are actually full-cell potential (difference(s)) *versus* SHE...  
... or other another electrode... like  $\text{AgCl}(\text{s})/\text{Ag}(\text{s}), \text{Cl}^-(\text{aq})$ ... or the local vacuum level!

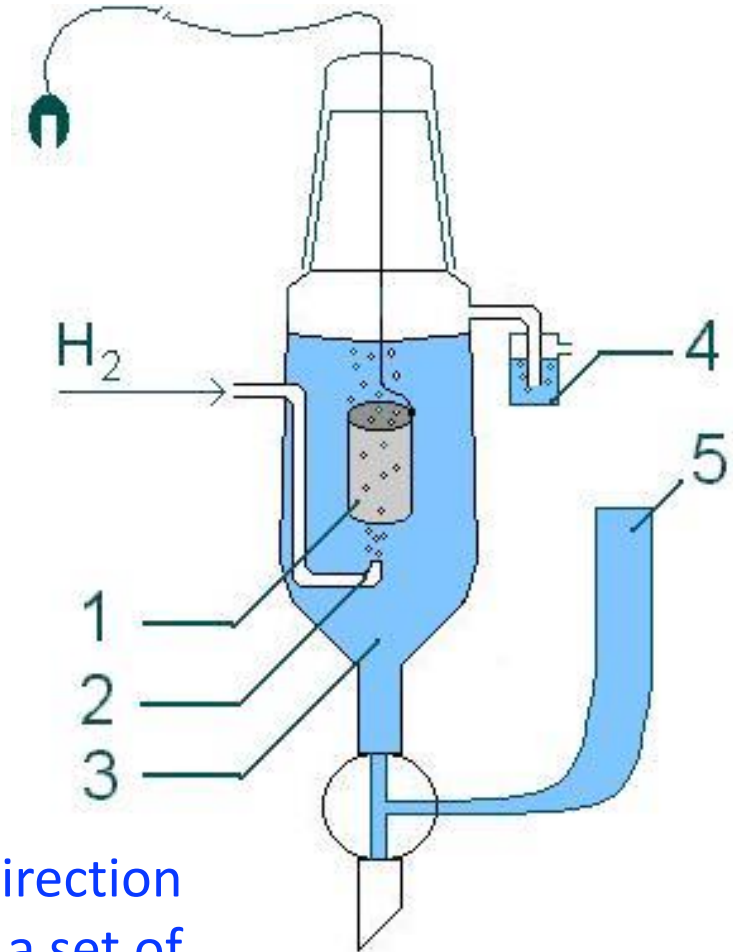

\* one rendition of an experimental SHE



# Nernst Equation

“Half-reactions”, at non-unity activity, obey the Nernst equation...

... take  $\Delta G = \Delta G^0 + RT \ln Q$  and use the relation  $\Delta G = w' = zq\phi = -nFE$ ,



$$Q_c = \frac{[C]^c [D]^d}{[A]^a [B]^b}$$

... look what I found... this is incorrect... but why?... what can we do to fix this?

... and at 298.15 K,  $E = E^0 - \frac{0.05916 \text{ V}}{n} \log Q$

$$-nFE = -nFE^0 + RT \ln Q$$

$$E = E^0 - \frac{RT}{nF} \ln Q$$

$$E = E^0 - \frac{RT \log Q}{nF \log e}$$

$$E = E^0 - \frac{RT}{0.4343nF} \log Q$$

$$E = E^0 - \frac{2.3026RT}{nF} \log Q$$

Reaction quotient...  
... product and quotient  
of species activities

Physicist

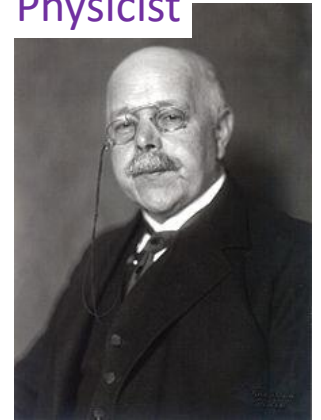

Walther Hermann Nernst  
(1864–1941)  
Nobel Prize (Chemistry, 1920)  
from Wiki

... memorize ~60 mV per order in  $\log_{10}$ , but do not forget  $n$  and that this is at 25 °C!

# A Brief History Lesson on Electrochemistry

Electrochemistry is associated with Luigi Galvani who discovered “animal electricity” ... while trying to Frankenstein frogs legs (1791)

Physician, Physicist, Philosopher

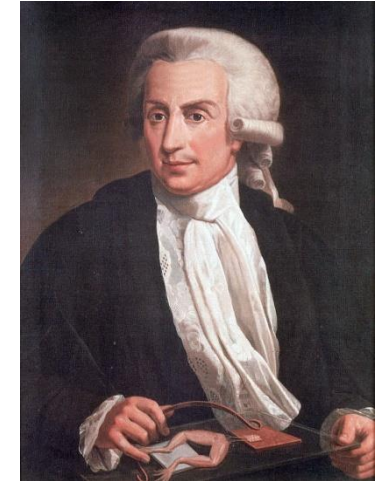

Luigi Galvani  
(1737–1798)  
from Wiki

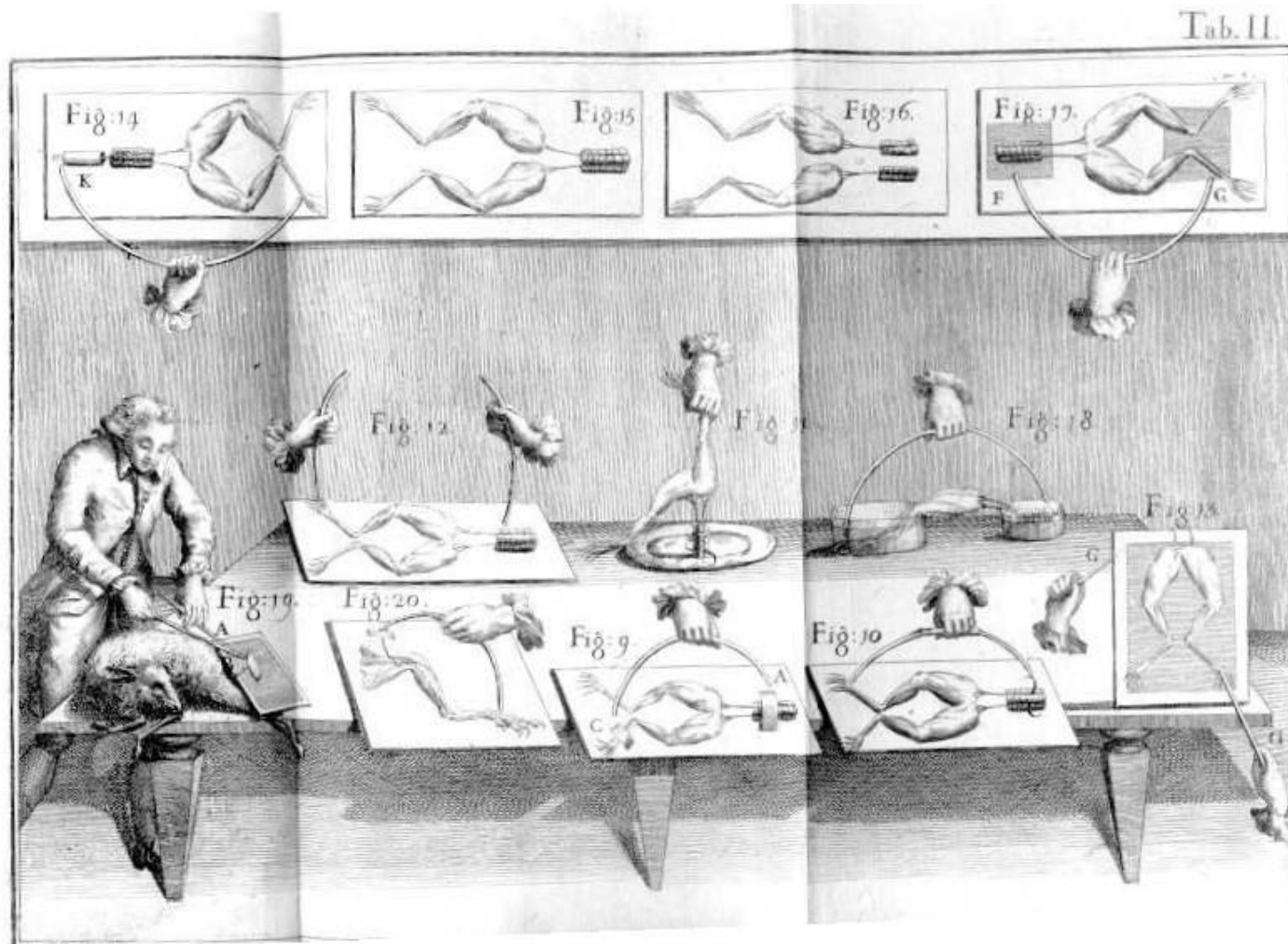

# (Almost) The First Battery: the Voltaic Pile

Invented by Alessandro Volta (1800), but...

... the elements of the pile (**galvanic cells**) were named after Galvani

Physicist

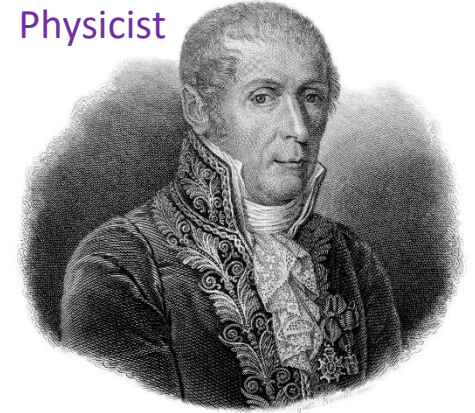

Alessandro Volta  
(1745–1827)  
from Wiki



At the Tempio Voltiano (the Volta Temple)  
near Volta's home in Como, Italy.

[http://en.wikipedia.org/wiki/Voltaic\\_pile](http://en.wikipedia.org/wiki/Voltaic_pile)

What are the  
combined half-  
reactions?

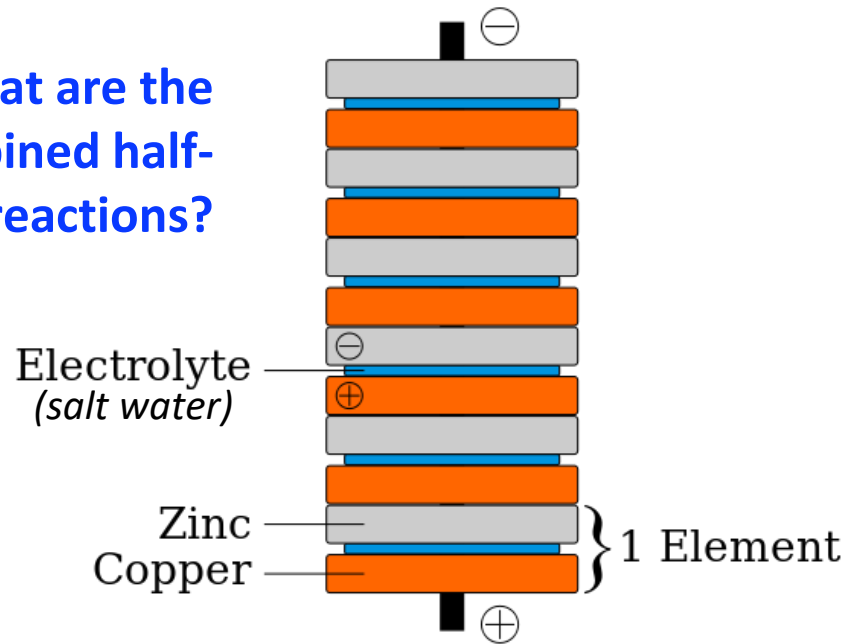

Volta presenting his "Voltaic  
Pile" to Napoleon and his  
court... and now he is a Count!



[http://en.wikipedia.org/wiki/Alessandro\\_Volta](http://en.wikipedia.org/wiki/Alessandro_Volta)



# Galvanic Cells

**Every non-equilibrium cell is a galvanic cell (in one direction, i.e. the spontaneous direction)**

Physically separating the half-reactions allows the electrons to go over a long distance, from the anode to the cathode via a (solid) conductor: basis for conversion of chemical energy into electricity = “Electrochemistry”!

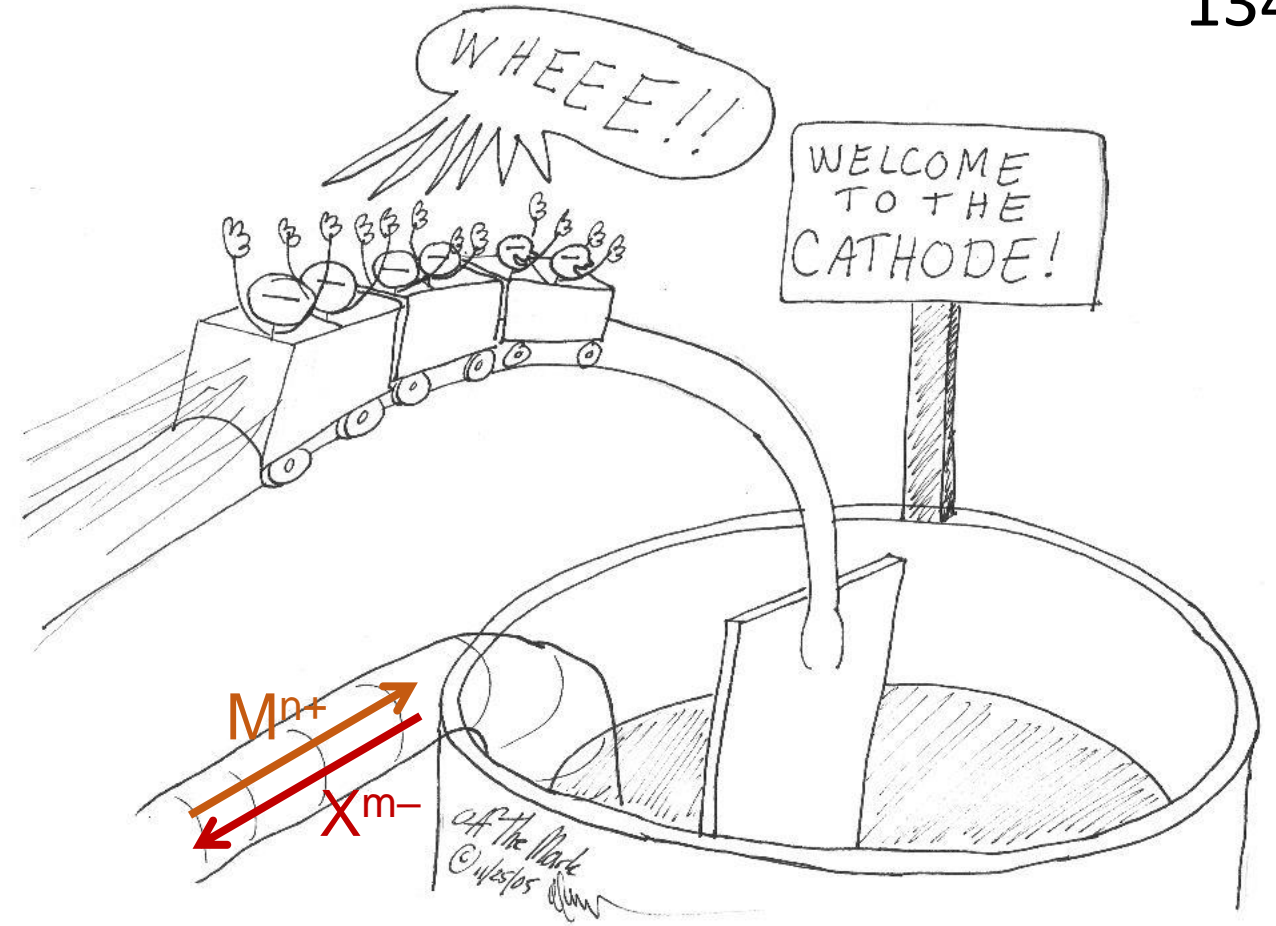

**Salt bridge** is an ionic conduit to prevent capacitive buildup of charge in both compartments and also to prevent bulk mixing of the two solutions

# Electrolysis of Water

Chemist

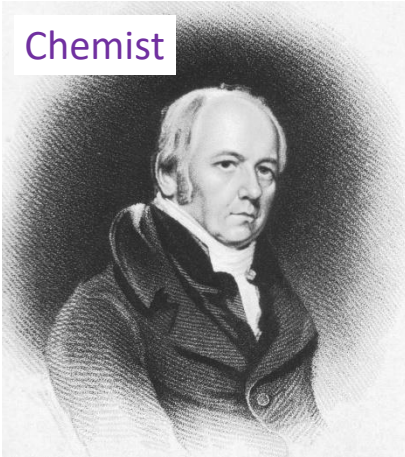

William Nicholson  
(1753–1815)

Surgeon



Sir Anthony Carlisle  
(1768–1840)

Chemist



Johann Wilhelm Ritter  
(1776–1810)

Chemist

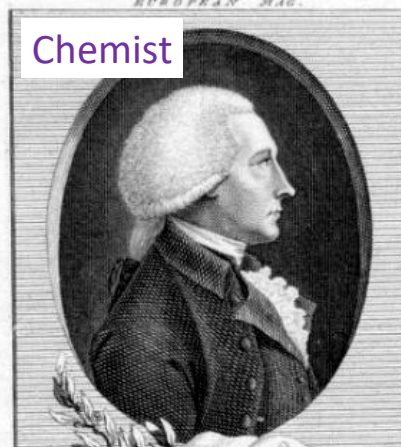

William Cruickshank  
(17??–1810(1))

Volta's results were shared with the scientific community and then, *boom*, many people demonstrated electrolysis the same year, and later electroplating!

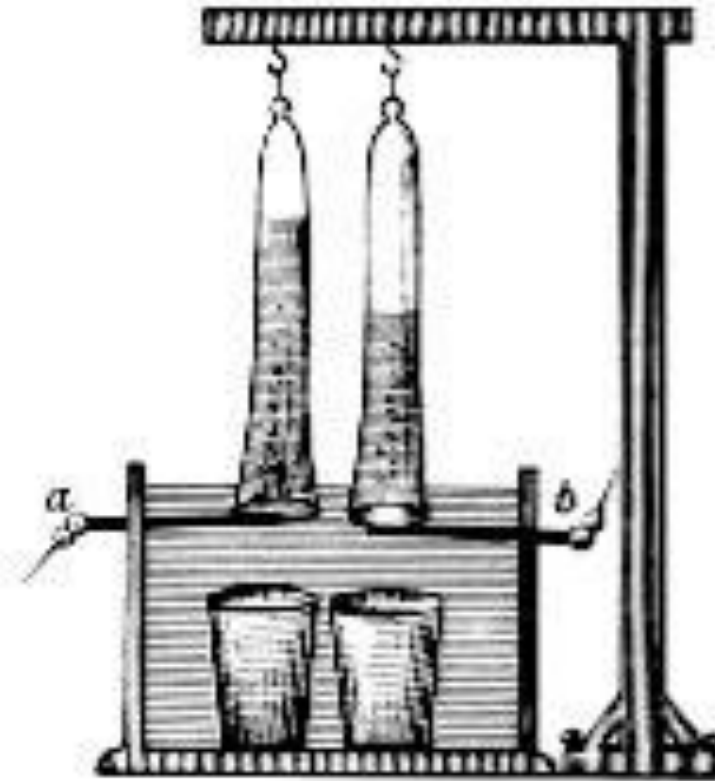

[http://en.wikipedia.org/wiki/Johann\\_Wilhelm\\_Ritter](http://en.wikipedia.org/wiki/Johann_Wilhelm_Ritter)

# The First Battery: the Daniell Cell (1836)

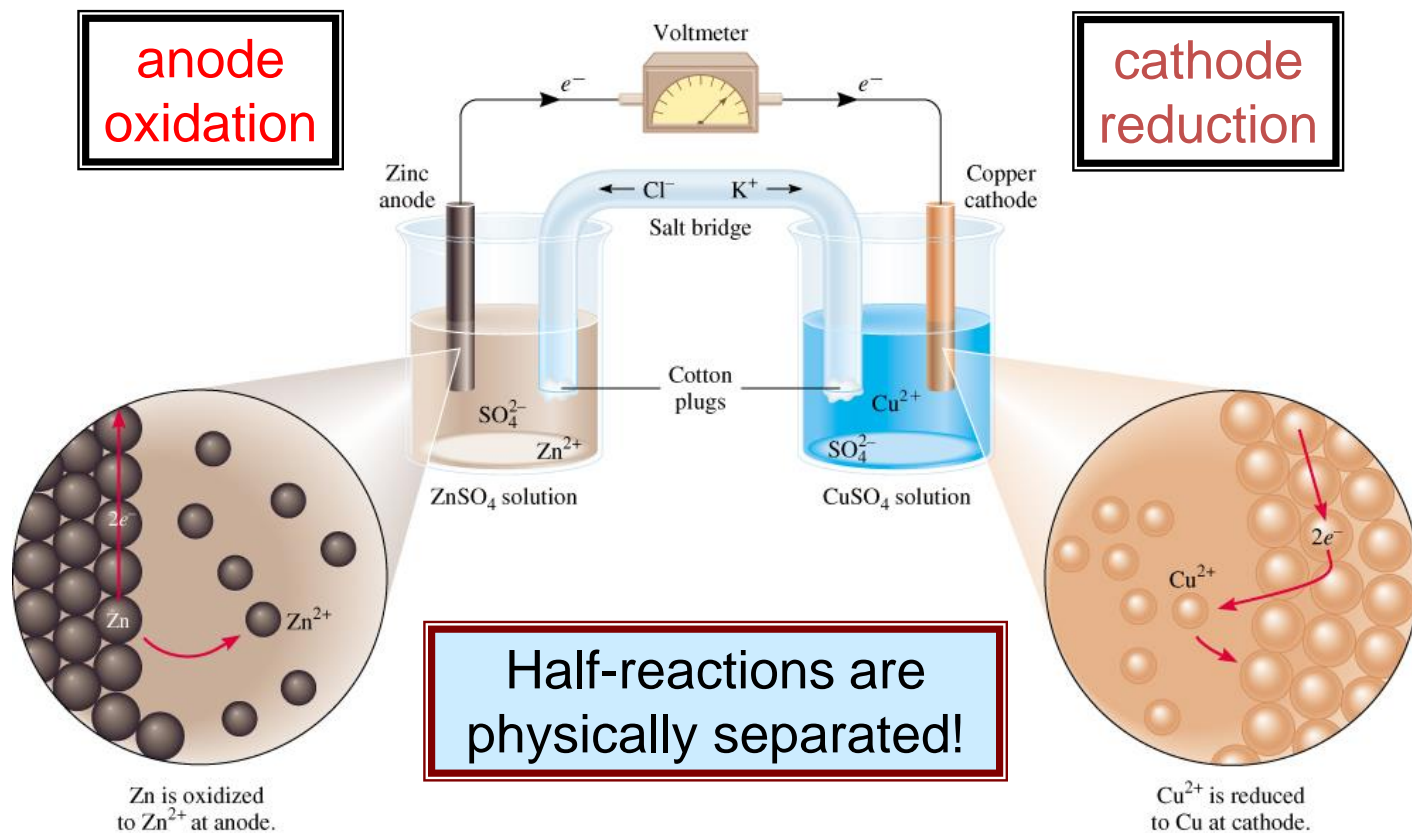

No more H<sub>2</sub> from a (primary) galvanic cell... meaning non-rechargeable battery!

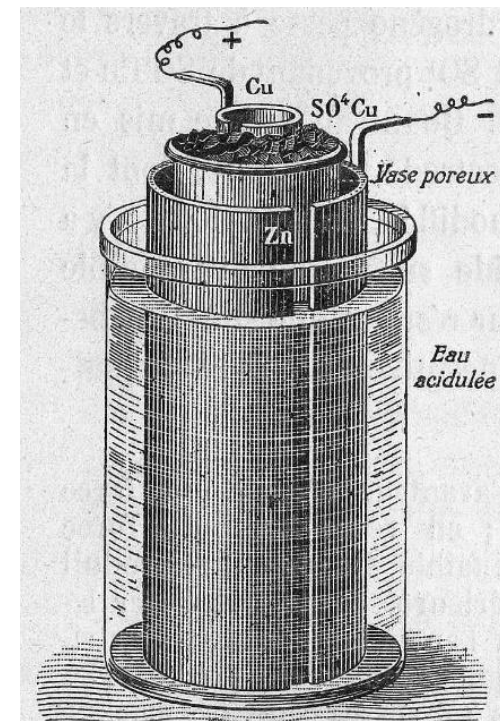

Chemist, Meteorologist



John Frederic Daniell  
(1790–1845)

from Wiki

... the net reaction occurs when Zn(s) is immersed into CuSO<sub>4</sub>(aq)... **spectator ions**, e.g. SO<sub>4</sub><sup>2-</sup>, are omitted  
 ... EChem gives you a way to drive the reaction backward... using electricity to perform chemical work



# Acronym's Anyone?

## OIL RIG

- **Oxidation**
- **Is**
- **Loss.** (of electrons)
  
- **Reduction**
- **Is**
- **Gain.** (of electrons)



... Ugh!... you didn't hear this from me!

# Conventions... Oh, Conventions!

Cathode – electrode where catholyte species are reduced

Anode – electrode where anolyte species are oxidized

Does a Negative/Positive Electrode = Cathode or Anode?... It depends!

For the discharging (galvanic) battery, label the anode and the cathode.

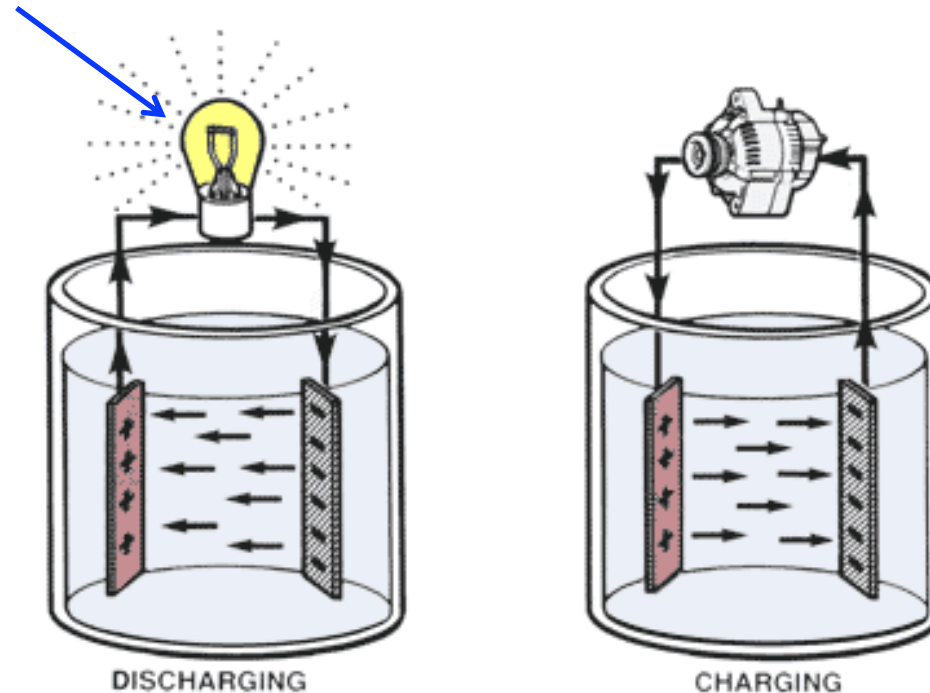



# Conventions... Oh, Conventions!

Cathode – electrode where catholyte species are reduced

Anode – electrode where anolyte species are oxidized

Does a Negative/Positive Electrode = Cathode or Anode?... It depends!

For the charging (electrolytic) battery, label the anode and the cathode.

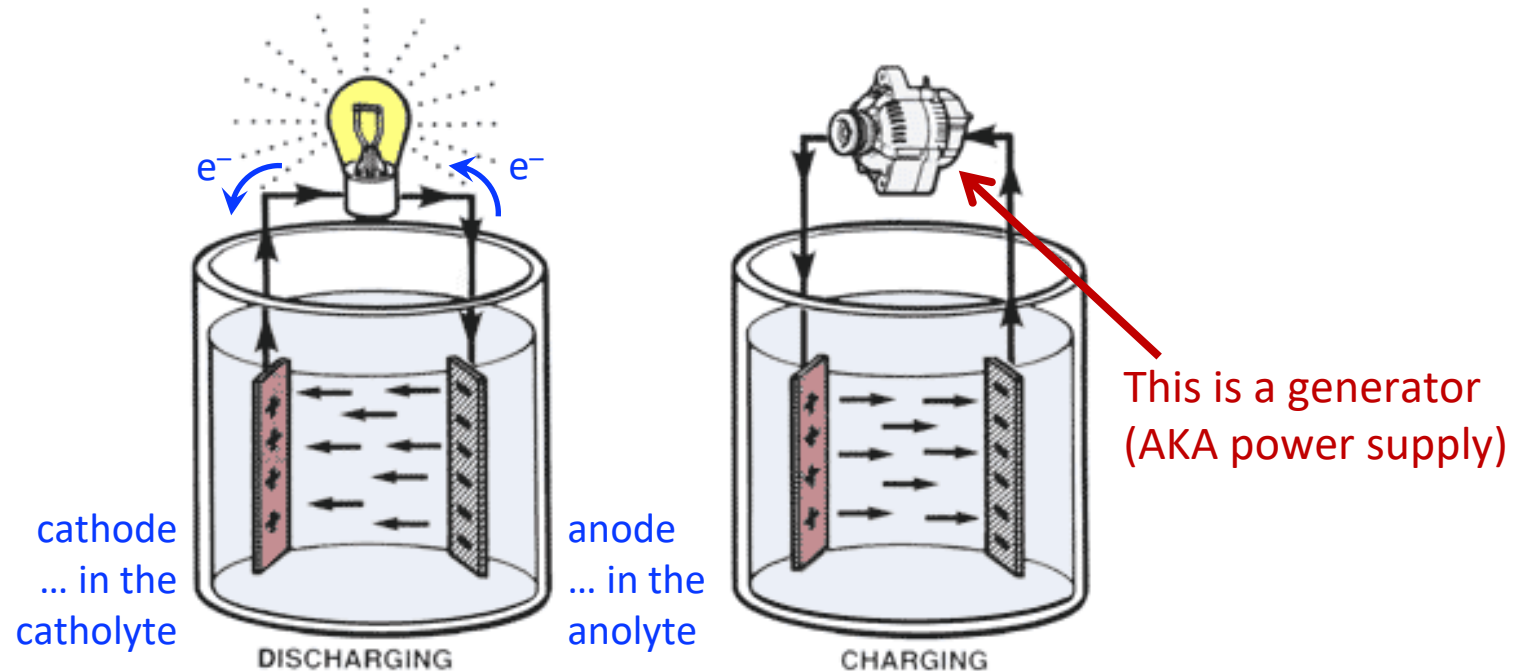

# Conventions... Oh, Conventions!

**Positive electrode** – positively charged; immersed in the **posolyte**

**Negative electrode** – negatively charged; immersed in the **negolyte**

... I'm not kidding!

... Sheesh!...

... Take-home message: For batteries, don't call electrodes anodes and cathodes (but the naming convention used by most is for discharge)

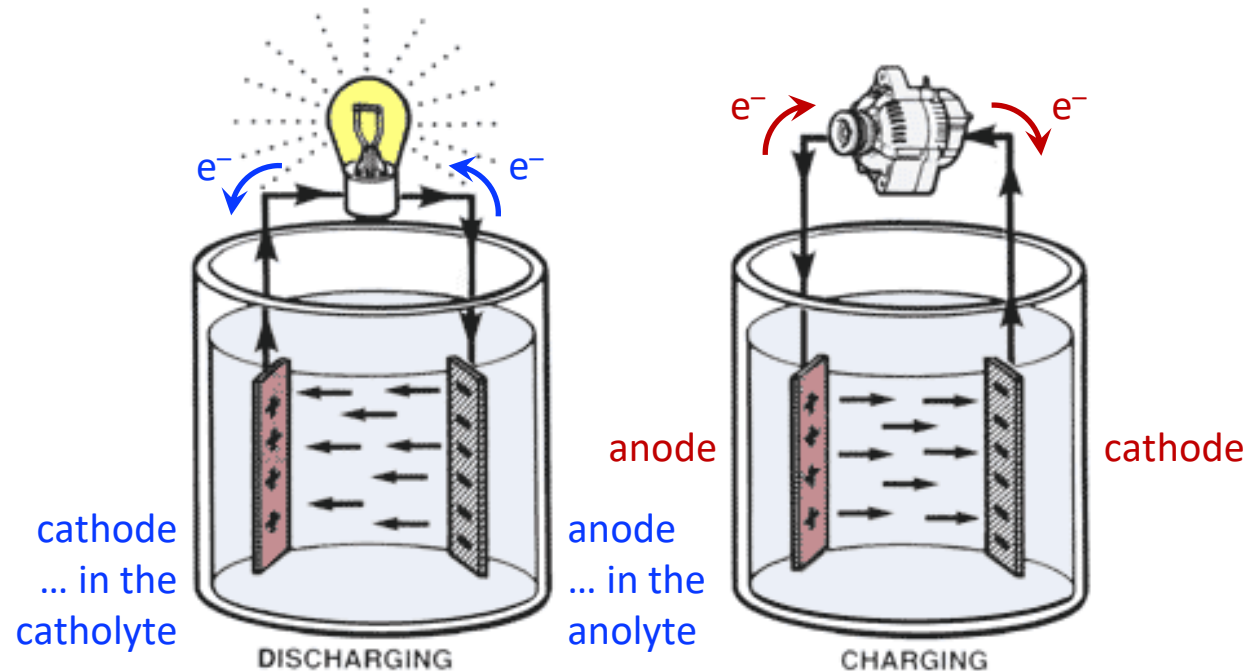

# Conventions... Oh, Conventions!



# Conventions... Oh, Conventions!

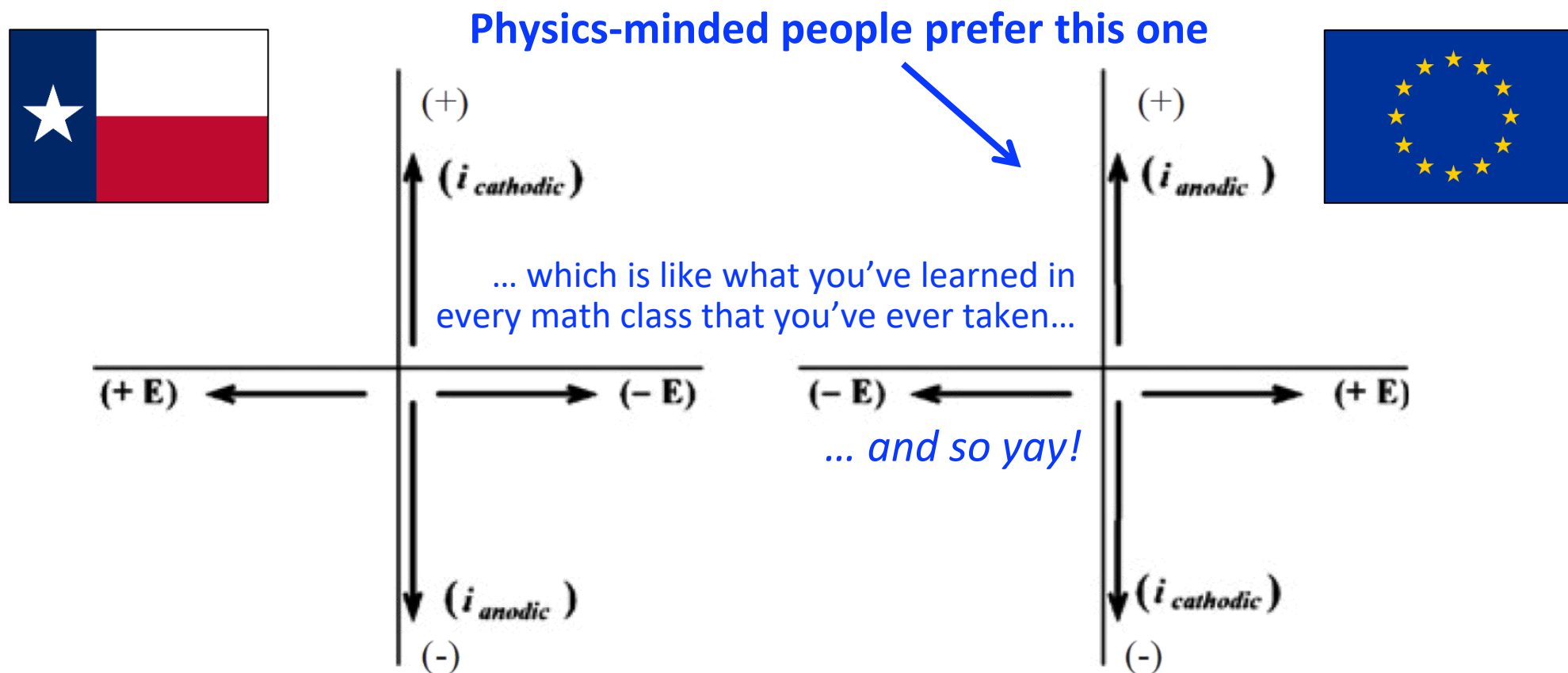

**Figure 1.1** American (left) and IUPAC (right) voltammogram conventions.

... Sadly, one of the top Electrochemistry textbooks by Bard & Faulkner uses the convention on the left...  
 ... which makes learning electrochemistry harder than it needs to be... Ugh!

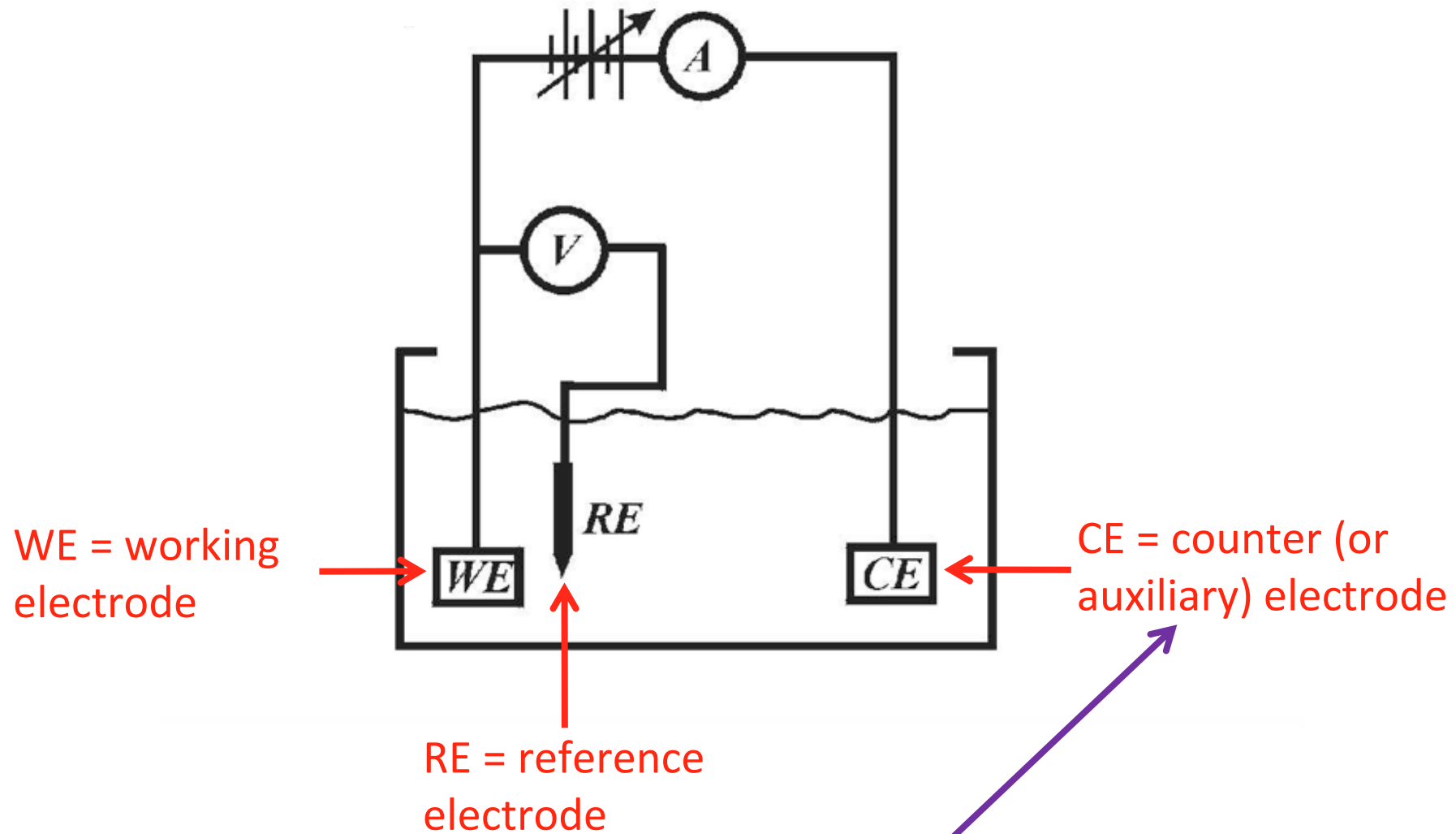

“Out of sight, out of mind” is a telling proverb!

# Charged Interfaces (*summary for today*)

- Vacuum level, Redox half-reactions
- Nernst equation
- History, Conventions
- Electrodes, Potentiostat
- Electric double layer
- Electric potentials, Liquid-junction potentials, Donnan potential, Membrane potential
- pH probe, Acidity scale, Titrations, Buffering, Henderson–Hasselbalch equation
- Latimer diagram, Pourbaix diagram

**Paper Time!**